

IAAI Field Manual

Evaluation of Vacant and Abandoned Properties



IAAI/USFA Abandoned Building Project



IAAI Field Manual
Evaluation of Vacant and Abandoned Properties

Developed By

The International Association of Arson Investigators, Inc.

12770 Boenker Road
Bridgeton, MO 63044

www.firearson.com

Project Manager

Jon C. Jones

Jon Jones & Associates
Lunenburg, MA

Funded By

The United States Fire Administration

Grant No. EME-2000-GR-0519

Preface

Shortly after the tragic fire in Worcester, Massachusetts that took the lives of six firefighters in an vacant building in 1999, the leadership of the International Association of Arson Investigators, Inc. began planning a program that would increase awareness of the hazards that vacant and abandoned buildings pose within communities. In October of 2000, the United States Fire Administration awarded a grant to assist the IAAI in this effort.

The objective of the initial project was, the development of materials to assist public officials in dealing with vacant or abandoned buildings within their jurisdictions. Materials developed as part of the project were targeted toward the safety of fire suppression forces involved in fighting fires in vacant or abandoned buildings and the reduction of incendiary fires involving these properties. Materials developed as part of the project were to become a "Tool Box" that community leaders could select from to address vacant and abandoned buildings and the hazards they represent.

In 2003, the United States Fire Administration awarded a second grant to assist the IAAI in review and update of the Tool Box materials. As part of this effort, the *IAAI/USFA Vacant/Abandoned Building Evaluation Form* that was included in the original Tool Box was reviewed and updated. The intended audience for this IAAI Field Manual includes emergency response personnel as well as fire and building code enforcement officials assigned the task of evaluating vacant and abandoned properties. The information in the manual is organized using the major subdivisions of the Inspection Form. The Field Manual is intended to be used in the field to assist inspectors in the evaluation of properties and as a training tool for personnel assigned these responsibilities.

Project staff would like to thank the membership of the International Association of Arson Investigators, Inc. for their input into this program and advise regarding the development of new materials. A special note of thanks goes to Susan Salzman of the City of Champaign, IL Neighborhood Services Department, for reviewing and commenting on the material as it was developed.

Table of Contents

1. Purpose and Scope.....	1
2. Basic Evaluation Procedures.....	2
3. Building Security	5
4. Utilities.....	6
5. Building Use	7
6. Building Construction.....	8
7. Fire Protection Systems	11
8. Fire Growth Potential.....	12
9. Exposures	14
10. Fire Suppression Operations.....	15
11. Hazardous Materials	16
12. Conditions That Require Immediate Action	17
13. Analysis of the Building.....	18
14. Completing the Evaluation	21
15. Posting Recommendation.....	21
Appendix 1 Evaluation Form	22
Appendix 2 Building Security.....	24
Appendix 3 Building Markings	30

1. Purpose and Scope

This field manual provides guidance for the inspection and evaluation of vacant or abandoned properties using the *IAAI/USFA Vacant/Abandoned Building Evaluation Form* (Appendix 1). To be effective, vacant buildings should be evaluated early in the vacancy cycle to identify potential hazards and to provide emergency responders with vital information for use in the event of fire or other emergency in the building. The data developed during this process can also be used in the decision making process where limited funds must be allocated to address the most significant problems.

The terms “vacant” and “abandoned” are often used interchangeably when talking about these buildings. There is, however, a subtle difference in the terms. Black’s Law Dictionary defines **vacant** as “empty; unoccupied”. The word **abandon** is defined as “to desert, surrender, forsake or cede. To relinquish or give up with intent of never again resuming one’s right or interest.” When dealing with buildings, the difference between vacant and abandoned is primarily related to the availability of an owner. Unoccupied buildings where there is a viable owner, i.e. one that is interested in the property and easily contacted, are considered vacant. Where there is no viable owner or an absentee landlord, the property is generally considered abandoned. Unoccupied properties that are secure and well maintained do not pose the level of threat to public safety as properties that are unoccupied and open to unauthorized access.

Vacant and abandoned structures are unsightly, attract criminal activity, and are a threat to public safety wherever they exist. The National Fire Protection Association (NFPA) estimates that more than ten civilians die and 6000 firefighters are injured while fighting fires in these properties every year. NFPA statistics also show that more firefighters are injured while operating at fires involving vacant or abandoned properties than in any other property classification.



2. Basic Evaluation Procedures

2.1 Collecting Property Data

The evaluator should normally be provided with basic information regarding the property they are assigned to inspect. That information will almost always include the address of the property to inspect. However, there may be times when the evaluation is driven by an incident or event involving the building. In that event, the first responder will have to gather as much of the basic information listed at the top of the evaluation form as possible. In situations where the owner is not known, the evaluator may be able to obtain information from neighbors or materials found during the inspection.

2.2 Right of Entry

Under non-emergency conditions the evaluator must have permission from the owner prior to entering the property to conduct the inspection. The authority to inspect is typically outlined in the codes and ordinances adopted by the jurisdiction. The evaluator should know the right of entry procedures applicable to the jurisdiction and carefully follow them. Where permission can not be obtained from an owner, many jurisdictions have the ability to obtain administrative warrants that allow legal entry to properties.

Where permission to enter a property has not been granted, and an evaluation is deemed necessary, basic information should be collected without trespassing, by making observations for the public way, or from adjacent properties that the evaluator has been granted entry.



2.3 Conducting the Evaluation

The evaluator should keep in mind that the purpose of the inspection is to obtain basic information about a vacant property that can be used by emergency responders and in the decision making process regarding the disposition of a specific property. The *IAAI/USFA Vacant/Abandoned Building Evaluation Form* shown in **Appendix 1** of this manual is designed to serve as a guide to the collection of essential information regarding the vacant property. The amount of time required to complete the evaluation will depend on the size and complexity of the structure. The evaluation process outlined in this manual is primarily a survey of the property. It is not intended to provide an engineering analysis of the structure. **The evaluator is looking for obvious indications of problems involving the site, the building and it's contents.**

The objectives of the evaluation are:

- To determine that the building is secure
- To identify hazards that require immediate corrective action
- To evaluate the fire growth potential of the building
- To evaluate the potential for structural collapse
- To identify conditions that could be hazardous to personnel entering the building under emergency conditions (Fire, Police, EMS)

The evaluation should begin with a walk around the outside of the building to determine the general layout, security and condition of the structure. Other information such as the type and status of utilities and signs of unauthorized entry should be noted during the initial walk around. If the evaluator determines that the structure is safe to enter, and they have permission to do so, the interior of the structure should then be examined.

As part of the evaluation, a simple diagram of the building should be drawn. The diagram should include a floor plan of the building with the location of hazards, utility entrances, fire suppression system control valves and connections and other potentially useful information. Based on the procedures of the local jurisdiction the evaluator may also elect to use a camera to document conditions and hazards found during the evaluation. Photos are very useful in developing preplans for emergency responders as well as tracking the deterioration of a property that remains unoccupied for a long period of time. If photos are taken the location photographed should be noted on the diagram for future reference.

2.4 Safety

Personnel conducting evaluations of vacant and abandoned properties should be aware that these structures are inherently more dangerous than occupied properties. Evaluators should use extreme caution while working in and around these properties. Potential hazards that the personnel should consider include:

- Unstable structure
- Unprotected holes or shafts
- Fall and trip hazards
- Standing water in basements
- Vermin and potentially dangerous animals
- Hazardous materials abandoned on the property
- Unauthorized occupants
- Ongoing criminal activity in, or adjacent to, the property

Evaluations of vacant and abandoned properties should be conducted by teams, not individuals. The teams should have a means of emergency communication and their location should be known by a responsible party such as a supervisor or dispatcher.

Personnel entering buildings should have personnel protective equipment including:

- Flashlight
- Hard hat
- Work boots
- Gloves
- Eye protection
- Radio or mobile phone



Prior to entering a building to conduct an evaluation the team should use information from the exterior survey to identify potentially dangerous areas that should be avoided during the interior survey. While in the structure, the team should constantly evaluate its stability and safety. Any area that appears to be unstable should be avoided. If the stability of the structure is questionable, the team should not enter the building.

3. Building Security

Building Security		
<input type="checkbox"/> Secure	<input type="checkbox"/> Open/unsecured	<input type="checkbox"/> Signs of recent entry

The security of the building being evaluated is a key factor in the evaluation process. Buildings that are open to the elements and unauthorized access will degrade more rapidly than those that are intact and secure. While a vacant property is waiting for demolition or re-use, it must be properly secured to prevent unauthorized entry. The importance of proper security is demonstrated by National Fire Protection Association's estimates that more than 72 percent of fires reported in vacant or abandoned structures are of incendiary or suspicious origin. An additional 5 percent of the fires result from children playing with matches.

A structure that is located in a reasonably stable neighborhood may be secured by simply closing and locking all exterior doors and windows. Where unauthorized entry is an issue, more stringent security measures including fencing and board up may be required to prevent entry. **Appendix 2** of this manual discusses building security in more detail.



During the evaluation, it should be easy to determine the security of the building during the initial walk around. The evaluator should be looking for open, broken or missing doors and windows, or holes in the exterior walls that can be used to gain access to the building. If the building is boarded up, the evaluator should look for openings where the security measures have been breached or damaged.

When conducting the interior assessment, the evaluator should be alert to signs of recent entry into the building including: trash and litter, furnishings in an empty building, and signs of recent heating or cooking fires. Looking at dates on empty food or drink containers found in a building can be an indication of when the unauthorized activity has occurred.

4. Utilities

Utilities (Note Entry Points for each active utility on sketch)
Active Utilities <input type="checkbox"/> No <input type="checkbox"/> Yes If Yes: <input type="checkbox"/> Gas <input type="checkbox"/> Electricity <input type="checkbox"/> Oil <input type="checkbox"/> Water

Determine the status of utilities connected to the building. Observe the status of utility meters and valves on the outside of the building during the exterior survey. During the evaluation of the interior, the status of the remaining utilities should be determined.

The importance of collecting information regarding utilities is to determine if these are potential sources of ignition in the building from heating or power distribution systems and to document the location of devices that emergency responders can use to control the utilities. Additionally, if fire detection and suppression systems are provided, it is important to know if there is electricity and water available and if the building is heated to prevent freezing.

The point of entry of each utility provided should be noted on the building sketch.



5. Building Use

Building Use (The original use of the building and how it was last used)

The original use of a structure will provide the evaluator with clues to potential hazards that may be present. For example, when inspecting an industrial building, the evaluator can expect to find pits or shafts for machinery as well as hazardous materials including asbestos, PCB's in transformers, or oil contamination.

If the building has had other uses prior to becoming vacant, the evaluator should look for modifications to the structure or interior finish that could create a hazard, such as removal of fire barriers and walls, removal of equipment that creates unprotected pits or fall hazards, the



addition of combustible interior finish, or the storage of materials that could be hazardous in the event of a fire.

6. Building Construction

Building Construction	
Number of Floors _____	Basement: <input type="checkbox"/> Yes <input type="checkbox"/> Sub-Basement <input type="checkbox"/> Multi Sub-Levels
Exterior Walls <input type="checkbox"/> Block/Brick <input type="checkbox"/> Curtain Wall <input type="checkbox"/> Wood <input type="checkbox"/> Metal Tie Rods (stars)	
Openings in Exterior Walls <input type="checkbox"/> Many <input type="checkbox"/> Few <input type="checkbox"/> Windowless (Windows, Doors, etc.)	
Structural Members <input type="checkbox"/> Steel <input type="checkbox"/> Concrete <input type="checkbox"/> Wood <input type="checkbox"/> Mixed (Describe) (Beams, Girders, Columns)	
Truss Construction <input type="checkbox"/> Roof <input type="checkbox"/> Floors	
Exposed Structural Members <input type="checkbox"/> Yes <input type="checkbox"/> No (Beams, Girders, Columns & Trusses)	
Ceiling Type <input type="checkbox"/> None <input type="checkbox"/> Suspended <input type="checkbox"/> Metal <input type="checkbox"/> Sheetrock/Plaster <input type="checkbox"/> Wood	

Building construction is a key component of the evaluation of a vacant or abandoned building. The primary objective of the evaluator is to document the **observable** construction elements of the building. The information collected will be used in the evaluation of the potential for the building to withstand fire impingement, and the potential for structural collapse as a result of fire or the deterioration of the structure. This evaluation is not intended to be an engineering analysis of building construction.

The information collected during the exterior survey should include:

- The number of floors and indications of basements and subbasements
- The type of construction used for the exterior walls of the building
- Components that could lead to early structural failure in the event of a fire (i.e. metal tie rods with star anchors)
- The type and number of openings in the exterior of the building (For use in evaluating security, potential for fire exposure, and fire fighting operations)

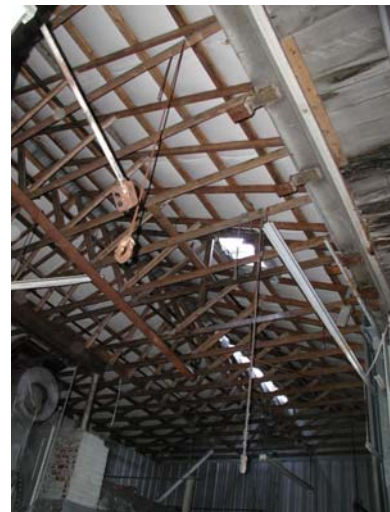

Condition of Interior Walls and Floors (Integrity of compartmentation)			
<input type="checkbox"/> Good	<input type="checkbox"/> Deteriorating	<input type="checkbox"/> Multiple penetrations that would allow fire spread	<input type="checkbox"/> Walls
Condition of Roof			<input type="checkbox"/> Floors
<input type="checkbox"/> Good	<input type="checkbox"/> Some instability/deterioration	<input type="checkbox"/> Major deterioration	
General Condition of Structure			
<input type="checkbox"/> Good	<input type="checkbox"/> Minor structural instability	<input type="checkbox"/> Major deterioration of structural elements	

The second element in the evaluation of construction of vacant and abandoned buildings is the assessment of the condition of the structural components. The evaluator should look for indicators of deterioration or instability, such as deformed walls or obvious deterioration of structural members. Conditions that lead to deterioration in these properties include:

- Exposure to the elements
- Damage done during the removal of contents such as machinery
- Removal of pipes, wiring and other building systems – urban mining
- Intentional damage by vandals and unauthorized occupants, such as cutting holes in the floors and walls

The first consideration is the condition of the interior walls and floors. Review the condition of walls and floors to determine if there are holes in the walls and floors that would allow a fire to rapidly spread, room to room, floor to floor, or reduce the structural stability of the building.



The second consideration is the condition of the roof system. The roof is designed to keep the elements out of the structure. If it has deteriorated, moisture can enter the building and cause additional deterioration. Additionally, if the roof system is unstable or deteriorated, it poses a significant hazard to firefighters attempting to establish ventilation in the event of a fire.

The final consideration in this section is the general condition of the structure. The evaluator should be alert to conditions that could cause the structure to fail more rapidly such as fire or high wind. The potential for the structure to fail due to advanced deterioration should also be considered. In other words, has the structure deteriorated to the point that gravity alone could cause the building or major components to fail?

7. Fire Protection Systems

Fire Protection Systems			
Operational Fire Alarm System	<input type="checkbox"/> Yes	<input type="checkbox"/> No	
Operational Sprinkler System (Valves open, pressure showing on gauges)	<input type="checkbox"/> Yes	<input type="checkbox"/> No	<input type="checkbox"/> System off, but usable if supplied through FD connection
Operational Standpipe System	<input type="checkbox"/> Yes	<input type="checkbox"/> No	
Fire Department Connection (If Yes, note location on sketch)	<input type="checkbox"/> Yes	<input type="checkbox"/> No	

When buildings are evaluated early in the vacancy cycle there is a good chance that installed fire protection systems will be found intact. Many local codes and ordinances require that existing systems be maintained by the building owner. The evaluator should determine if there are fire detection, alarm or suppression systems in the building and if they are operational. If there are operational systems, are the alarms they generate monitored or local only?

This portion of the evaluation will relate to the availability of utilities and building services such as electricity, water and heat in the case of automatic sprinklers.



Where automatic sprinkler systems are installed, it should be determined by visual inspection if the system is intact. If the supply valves are closed, could it function by feeding the fire department connection? This information could be critical in the decision making process in the event of a fire in the structure. Where sprinkler and standpipe systems are not intact, and a fire department connection is provided, marking the connection as **Out of Service** should be considered as a follow up to this evaluation.

8. Fire Growth Potential

Fire Potential				
Fuel Packages (Fuel Load)				
Quantity	<input type="checkbox"/> Numerous	<input type="checkbox"/> Moderate	<input type="checkbox"/> Limited	
Distribution	<input type="checkbox"/> Concentrated	<input type="checkbox"/> Spread out		
Housekeeping	<input type="checkbox"/> Good	<input type="checkbox"/> Poor		
Interior Finish	<input type="checkbox"/> Combustible	<input type="checkbox"/> Non-combustible	<input type="checkbox"/> Mixed (Describe)	
Room Size	<input type="checkbox"/> Large	<input type="checkbox"/> Moderate	<input type="checkbox"/> Small	
Potential for a delay in FD notification	<input type="checkbox"/> High		<input type="checkbox"/> Medium	<input type="checkbox"/> Low

This portion of the evaluation is designed to collect information about the potential for a fire to be ignited and grow within the structure. Keeping in mind that a fire needs an ignition source, fuel and oxygen to grow and develop, the evaluator should collect information that will assist in determining the fire growth potential of the building.

The term “fuel package” is used to describe the fuel that is available in a space or compartment. A fuel package is a discreet unit of fuel that will generate energy in the form of heat and light, as well as smoke and fire gasses, if it is ignited.

A typical fuel package in a living room of an occupied dwelling would be a sofa. In a compartment fire where the sofa is the first item ignited, the material it is constructed of, where it is located, and the proximity of other fuel packages will determine the fire growth in the space. It is common to find unusual fuel packages in vacant and abandoned buildings including large accumulations of debris or trash, furniture, and mattresses used by unauthorized occupants. When buildings are not secure the potential for unauthorized disposal of hazardous materials also exists. Trash accumulation in a compartment is not a normal



arrangement of fuels. Should these materials be ignited, fire growth and development may be more rapid and larger than normally expected.

Other fuels that the evaluator should watch for during the evaluation include combustible interior finish or exposed structural components. These components may have been covered when the building was in use and will add to the available fuel in the building. Watch for exposed insulation or other materials such as plastics that may ignite and burn rapidly.

Collecting information on room size is important when evaluating the fire growth potential as it will impact the magnitude of a fire in the building. Compartmentation plays an important role in limiting the growth of a fire in occupied buildings. Large unpartitioned spaces that are part of the building design, or the result of the removal of walls, floors, doors and other structural components can allow a fire in one part of the building to rapidly travel to other rooms or spaces.

The last element in this section is to estimate the potential for a delay in the notification of the fire department in the event of a fire. Time is a critical factor in fire growth and development. The longer a fire is allowed to burn, the more fuel it will consume. Delays in alarm often result in large fires that challenge the ability of the fire department to control and may require significant resources to fight.

Conditions that lead to a delay in the discovery of fires in vacant and abandoned properties include:

- The size of the building
- Buildings located in remote areas
- Buildings located in high crime areas
- Lack of functioning fire detection and alarm systems
- Security measures including boarded up windows and fences
- Buildings that are surrounded by other vacant or abandoned properties

Based on observations of the building and its surroundings, the potential for a fire to grow undetected should be estimated by the evaluator.

9. Exposures

Exposures (Note locations on sketch)				
Location	<input type="checkbox"/> A side	<input type="checkbox"/> B side	<input type="checkbox"/> C side	<input type="checkbox"/> D side
Separation (ft)	—	—	—	—
Occupied (Y/N)	—	—	—	—

This element of the evaluation is closely related to the Fire Growth section. This section asks the evaluator to look at potential exposures should the building burn. This information can be used to evaluate the potential for a fire to extend to adjacent structures. The identification system used is based on the common system of identifying sides of a fire building used by the fire service.

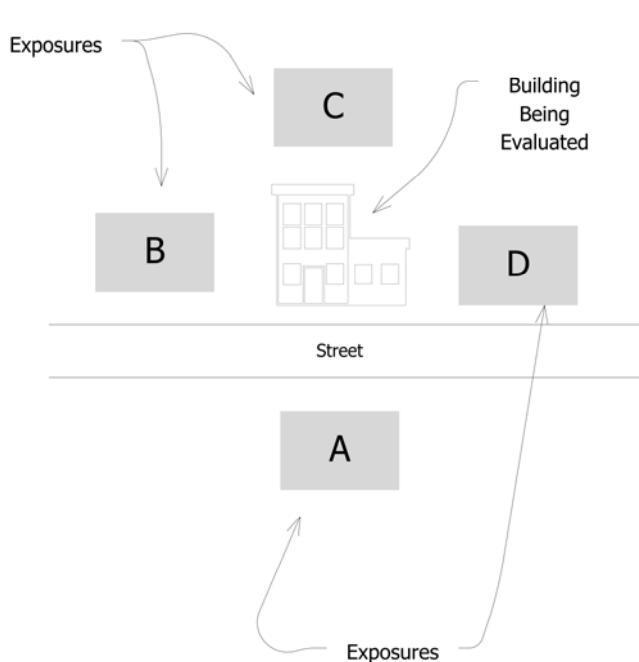

Information regarding the distance between exposures is used to evaluate the potential for fire extending to the exposed building. The greater the separation the better chance that the fire will not extend to the exposed structure. The number and types of openings in the exterior walls and the exposures determine the potential for an exposure fire.

The occupancy of each exposure determines the potential for a delayed alarm discussed in the Fire Growth Potential section above, as well as for fire department preplanning.

10. Fire Suppression Operations

Suppression Operations								
Hazards In Building	<input type="checkbox"/>	Holes in Floors	<input type="checkbox"/>	Missing Stairs	<input type="checkbox"/>	Open Shafts/pits		
Building Access:	<input type="checkbox"/>	4 sides	<input type="checkbox"/>	3 sides	<input type="checkbox"/>	2 Sides	<input type="checkbox"/>	Limited
Interior Layout	<input type="checkbox"/>	Complicated	<input type="checkbox"/>	Normal - Walls/Partitions	<input type="checkbox"/>	Open		
Water Supply:	<input type="checkbox"/>	Adequate	<input type="checkbox"/>	Inadequate	(Note Locations on Sketch)			

This element of the evaluation is designed to collect information regarding conditions in and around the vacant or abandoned structure that could present a hazard to firefighters in the event of a fire.

As the exterior and interior surveys are conducted, the evaluator should identify potential hazards in the structure such as holes in floors, missing stairs and open shafts and pits. These conditions are hazardous whenever the building is entered but present a significant hazard to firefighters operating with very low visibility due to smoke and steam.

The building access data provides basic information regarding the deployment of personnel and equipment, and the ability to get rescue personnel into the structure should firefighters require assistance.

Evaluating the interior layout is also related to the ability of firefighters to navigate through a building when visibility is reduced as a result of a fire. Be alert for unusual or maze like layouts that could cause firefighters to become disoriented.



The available water supply is included in this section as it is an important pre-fire planning consideration. The evaluation of the adequacy of the water supply should include the volume of water required to control the maximum potential fire at this location, including exposures. The location of fire hydrants or other water sources should be indicated on the sketch of the building site.

11. Hazardous Materials

Hazardous materials located on the site

(If Yes, describe in detail)

Yes None Observed

Vacant and abandoned properties are frequently used as a dumping spot for hazardous materials. Additionally, when a property is vacated the owner or former occupants may leave behind potentially hazardous materials. Should potentially hazardous or dangerous materials be observed during the evaluation the findings should be documented so that corrective action can be taken.

Evaluators should expect to find potentially hazardous materials in these buildings and operate accordingly during the evaluation process. That includes the use of proper personal protective clothing, adequate lighting during the evaluation, and avoiding contact with any material that could prove hazardous.



12. Conditions That Require Immediate Action

Conditions that require immediate correction Yes No
(If Yes, describe in detail)

Once the evaluation is complete conditions that require immediate corrective action should be identified. Conditions flagged for immediate action include:

- Serious collapse potential
- Accumulations of trash or debris in or near the structure that could serve as an initial fuel package for an intentionally set fire
- Hazardous materials located on the site
- Lack of security that permits unauthorized access to the building
- Indications of criminal activity on the site



Any condition on the property that could put civilians or emergency responders at risk should be identified in this section. Checking the **YES** box for this item serves as a flag for the evaluator that immediate action should be taken. The jurisdiction should implement a procedure to address these circumstances.

13. Analysis of the Building

Analysis of the building (provide **your** analysis of the building)

High	Moderate	Low
<input type="checkbox"/>	<input type="checkbox"/>	<input type="checkbox"/>
<input type="checkbox"/>	<input type="checkbox"/>	<input type="checkbox"/>
<input type="checkbox"/>	<input type="checkbox"/>	<input type="checkbox"/>
<input type="checkbox"/>	<input type="checkbox"/>	<input type="checkbox"/>

Potential for an exposure fire (extension to another building)

Potential for a Multi-Room fire on arrival of first due company

Potential for structural collapse early in the fire development

Potential for fire fighters to become lost or trapped during operations

The analysis section of the form provides the evaluator with the opportunity to use the information collected to rate the building. The ratings of **HIGH**, **MODERATE** and **LOW** are assigned to each of the listed conditions based on the knowledge and experience of the evaluator. A **HIGH** potential assigned to any of the conditions should trigger an in-depth review of the property and implementation of precautions to reduce the threat to the safety of emergency responders and the public.

The conditions used for this analysis include:

Potential for an exposure fire

The analysis of this condition is based on the proximity of adjacent buildings as discussed in the **EXPOSURE** section. The analysis is based on the separation of the buildings, the type of construction, and the potential for a delayed alarm that would allow a fire in one building to grow and extend to other structures. The type and number of openings in the walls of the buildings being evaluated, as well as the type of material used on the exterior of the exposed buildings, would enter into this evaluation. A **HIGH** rating indicates that there is significant potential for the fire to extend beyond the building of origin during the early stages of the incident. A **MODERATE** rating indicates that a fire could extend to the nearby exposures given the right circumstances such as high winds or a significant delay in an alarm. A **LOW** probability rating is assigned when the conditions that generally lead to an exposure concern are not a factor. This could be due to the distance between the building and the exposures, the type of construction of the buildings, or the likelihood of early detection should a fire occur.

Potential for a Multi-Room fire

This analysis is based on a combination of an unusual fuel load, combustible interior finish, and/or the lack of compartmentation within the building. Secondary factors include building construction, the deterioration of the interior structural elements (walls, ceilings, floor etc) and the potential for a delayed alarm. The significance of this condition is that fire units will be faced with a well established fire in the structure upon arrival. This relates to the need for increased firefighting resources early in the incident, as there is the potential for extension of the fire to adjacent buildings and early structural collapse. A **HIGH** rating on this condition indicates that there is a significant potential that the fire will be beyond the room of origin when the first fire suppression units arrive. A **MODERATE** rating indicates that some - but not all - of the factors that would cause the involvement of more than one room were found in the building, and under the right circumstances, a multi-room fire could occur early in the development of a fire. A **LOW** probability rating should be assigned to those buildings where compartmentation is in good condition, there is limited combustible material (interior finish, accumulated debris, or trash) and the probability of timely reporting of a fire is high.

Potential for structural collapse early in fire development

The analysis of this condition is based on the condition of the structure as well as the potential for multi-room fires and delayed alarms. As buildings begin to deteriorate due to exposure to the elements and/or vandalism, the integrity of the structure is reduced. This reduction in integrity, coupled with the damage a fire will cause, often leads to structural failure very early in the fire. A **HIGH** rating should be assigned where the building shows signs of deterioration due to exposure to the elements, previous fires, vandalism, or other signs that the structural integrity is compromised. A **MODERATE** rating indicates that there is limited deterioration of the structure, but fuel loading is normal and compartmentation is essentially intact. A **LOW** probability rating should be assigned to buildings that are basically in usable condition and would react to fire impingement on structural components in the same way as an occupied structure.

Potential for fire fighters to become lost or trapped

The analysis of this condition is based on the configuration and condition of the building at the time of the evaluation. Fire fighting operations are conducted under low visibility conditions due to smoke, steam and in many cases, at night. Conditions in a building that could result in fire fighters becoming disoriented or trapped while operating in or around a vacant/abandoned property include:

- Maze-like room configuration – Numerous small rooms off multiple corridors, holes cut into walls that lead into other building spaces
- Holes in floors or the roof system that fire fighters could fall into under low visibility conditions
- Intentionally placed Man traps in or around building
- Open shafts or pits in, or around the building, that fire fighters could fall into under low visibility conditions
- Debris or building systems that could entangle or entrap fire fighters and prevent escape
- Blocked or missing stairs that could prevent escape
- Limited building access that could reduce the egress or rescue options in the event of an emergency during fire fighting operations

A **HIGH** rating should be assigned where there are conditions that could readily result in disorientation or entrapment of fire fighters or other emergency personnel during emergency operations. A **MODERATE** rating indicates that there are conditions that could present a hazard to emergency responders, but these hazards are readily identified or protected so that they could be located under low visibility conditions. A **LOW** probability rating should be assigned to buildings that are basically in usable condition and present a hazard that is equal to an occupied structure in reasonable condition.

14. Completing the Evaluation

To complete the evaluation form the evaluator should write a brief narrative that describes the property and any hazards found. The narrative provides the evaluator with an opportunity to address issues that are not included on the Evaluation Form and to expand on issues that are identified but require additional information.

The final step in the process is the development of a readable sketch of the property to be included with the Evaluation Form. This is not intended to be a building plan, but a simple sketch that shows the basic layout of the property. Information needed to develop a fire operations pre-plan or to make decisions regarding the disposition of the building should be included on this diagram. Where the evaluators have access to computer based drawing programs, the rough sketch can be used to create a clean diagram that is annotated as described in this manual. Based on the jurisdiction, the diagram or building file may also include photos of the structure and property that can be used in the pre-planning and decision making process.

15. Posting Recommendation

Building Marking



Based on the information collected and the analysis of the building, a recommendation for posting of the building should be made. Posting should be in accordance with the procedures established by the jurisdiction. **Appendix 3** provides an example of a system used to alert emergency responders to hazardous conditions in a structure. Jurisdictions should also consider requiring the buildings to be posted with **No Trespassing** signs to assist law enforcement officials in managing unauthorized access.

If the analysis of the building indicates that there is a significant hazard to fire fighters or other emergency responders, it should be posted. A HIGH risk rating in any of the items in the Analysis Section should cause the building to be posted for exterior operations only.



Appendix 1 Evaluation Form

Date: / /

Building Marking



Vacant/Abandoned Building Evaluation Form

Address: _____

Property Name: _____

Owner Name: _____ Telephone: _____

Owner Address: _____

Answer each of the following questions about the building. Select multiple options, if necessary; explain response.
Draw a simple sketch of the location and explain your observations in a brief narrative.

<p>Building Security</p> <p><input type="checkbox"/> Secure <input type="checkbox"/> Open/unsecured <input type="checkbox"/> Signs of recent entry</p>
<p>Utilities (Note Entry Points for each active utility on sketch)</p> <p>Active Utilities <input type="checkbox"/> No <input type="checkbox"/> Yes If Yes: <input type="checkbox"/> Gas <input type="checkbox"/> Electricity <input type="checkbox"/> Oil <input type="checkbox"/> Water</p>
<p>Building Use (The original use of the building and how it was last used)</p>
<p>Building Construction</p> <p>Number of Floors _____ Basement: <input type="checkbox"/> Yes <input type="checkbox"/> Sub-Basement <input type="checkbox"/> Multi Sub-Levels</p> <p>Exterior Walls <input type="checkbox"/> Block/Brick <input type="checkbox"/> Curtain Wall <input type="checkbox"/> Wood <input type="checkbox"/> Metal Tie Rods (stars)</p> <p>Openings in Exterior Walls <input type="checkbox"/> Many <input type="checkbox"/> Few <input type="checkbox"/> Windowless (Windows, Doors, etc.)</p> <p>Structural Members <input type="checkbox"/> Steel <input type="checkbox"/> Concrete <input type="checkbox"/> Wood <input type="checkbox"/> Mixed (Describe) (Beams, Girders, Columns)</p> <p>Truss Construction <input type="checkbox"/> Roof <input type="checkbox"/> Floors</p> <p>Exposed Structural Members <input type="checkbox"/> Yes <input type="checkbox"/> No (Beams, Girders, Columns & Trusses)</p> <p>Ceiling Type <input type="checkbox"/> None <input type="checkbox"/> Suspended <input type="checkbox"/> Metal <input type="checkbox"/> Sheetrock/Plaster <input type="checkbox"/> Wood</p>
<p>Condition of Interior Walls and Floors (Integrity of compartmentation)</p> <p><input type="checkbox"/> Good <input type="checkbox"/> Deteriorating <input type="checkbox"/> Multiple penetrations that would allow fire spread <input type="checkbox"/> Walls <input type="checkbox"/> Floors</p> <p>Condition of Roof</p> <p><input type="checkbox"/> Good <input type="checkbox"/> Some instability/deterioration <input type="checkbox"/> Major deterioration</p> <p>General Condition of Structure</p> <p><input type="checkbox"/> Good <input type="checkbox"/> Minor structural instability <input type="checkbox"/> Major deterioration of structural elements</p>
<p>Fire Protection Systems</p> <p>Operational Fire Alarm System <input type="checkbox"/> Yes <input type="checkbox"/> No</p> <p>Operational Sprinkler System <input type="checkbox"/> Yes <input type="checkbox"/> No <input type="checkbox"/> System off, but usable if supplied through FD connection (Valves open, pressure showing on gauges)</p> <p>Operational Standpipe System <input type="checkbox"/> Yes <input type="checkbox"/> No</p> <p>Fire Department Connection <input type="checkbox"/> Yes <input type="checkbox"/> No (If Yes, note location on sketch)</p>

Appendix 1 Evaluation Form

Fire Potential			
Fuel Packages (Fuel Load)			
Quantity	<input type="checkbox"/> Numerous	<input type="checkbox"/> Moderate	<input type="checkbox"/> Limited
Distribution	<input type="checkbox"/> Concentrated	<input type="checkbox"/> Spread out	
Housekeeping	<input type="checkbox"/> Good	<input type="checkbox"/> Poor	
Interior Finish	<input type="checkbox"/> Combustible	<input type="checkbox"/> Non-combustible	<input type="checkbox"/> Mixed (Describe)
Room Size	<input type="checkbox"/> Large	<input type="checkbox"/> Moderate	<input type="checkbox"/> Small
Potential for a delay in FD notification		<input type="checkbox"/> High	<input type="checkbox"/> Medium <input type="checkbox"/> Low
Exposures (Note locations on sketch)			
Location	<input type="checkbox"/> A side	<input type="checkbox"/> B side	<input type="checkbox"/> C side <input type="checkbox"/> D side
Separation (ft)	___	___	___
Occupied (Y/N)	___	___	___
Suppression Operations			
Hazards In Building	<input type="checkbox"/> Holes in Floors	<input type="checkbox"/> Missing Stairs	<input type="checkbox"/> Open Shafts/pits
Building Access:	<input type="checkbox"/> 4 sides	<input type="checkbox"/> 3 sides	<input type="checkbox"/> 2 Sides <input type="checkbox"/> Limited
Interior Layout	<input type="checkbox"/> Complicated	<input type="checkbox"/> Normal - Walls/Partitions	<input type="checkbox"/> Open
Water Supply:	<input type="checkbox"/> Adequate	<input type="checkbox"/> Inadequate	(Note Locations on Sketch)

Hazardous materials located on the site Yes None Observed
 (If Yes, describe in detail)

Conditions that require immediate correction Yes No
 (If Yes, describe in detail)

Analysis of the building (provide <i>your</i> analysis of the building)	High	Moderate	Low
Potential for an exposure fire (extension to another building)	<input type="checkbox"/>	<input type="checkbox"/>	<input type="checkbox"/>
Potential for a Multi-Room fire on arrival of first due company	<input type="checkbox"/>	<input type="checkbox"/>	<input type="checkbox"/>
Potential for structural collapse early in the fire development	<input type="checkbox"/>	<input type="checkbox"/>	<input type="checkbox"/>
Potential for fire fighters to become lost or trapped during operations	<input type="checkbox"/>	<input type="checkbox"/>	<input type="checkbox"/>

Narrative:

Inspected by:

Posting Authorized by:

Data Entered by:

USFA National Arson Prevention Initiative
Board Up Procedures
Materials List and Specifications

Security Measures

1. All openings in the basement, first floor doors and windows, and any point of entry accessible from a porch, fire escape or other potential climbing point shall be barricaded with plywood, 2x4 braces, carriage bolt sets, and nails. Particle board, wafer board, Masonite, or other similar material shall not be used for purposes of boarding-up a building.
2. Openings that are at least 10' from ground level which are not accessible from a porch, fire escape, roof, or other climbing point can be secured with nails in each brace, and every 12" around the perimeter. For all openings, the plywood should be fitted so that it rests snugly against the exterior frame, butting up to the siding on wood frame buildings and up to the brick molding edge on brick buildings. It may be necessary to remove the staff bead so this fit can be flush and tight.
3. The structure shall be posted with a NO TRESPASSING sign at the completion of the board-up.

Materials

1. Plywood, 1/2" (4 ply) exterior grade CDX
2. Braces - 2" by 4" by 8' construction grade lumber
3. 3/8" (coarse thread) by 12" carriage bolts (rounded head on weather side)
4. 3/8" (coarse thread) construction grade nuts
5. 1/2" (USS Standard) Flat washers with an inside diameter large enough to bypass the wrench neck inside the carriage bolt head so no lift edge is available beneath an installed carriage bolt head.
6. 3/8" (USS Standard) diameter flat washers for installation beneath the nut inside the building
7. 1-5/8" (6d) galvanized or stainless steel ring-shank nails or comparable deck nails.

Appendix 2 Building Security

Barrier Assembly

1. Applying barriers is accomplished with an inside and outside carpenter with appropriate tools and supplies. The inside carpenter will need a light. Exit is made over a ladder when the last window is boarded.
2. Plywood shall be cut to fit over the window and door openings, flush with outside of the molding/trimmer stud. Application of barriers shall be completed so that all lift or pry points are avoided.
3. The 2x4 braces shall be cut to fit the horizontal dimension of the plywood. Two exterior and two interior 2x4 braces shall be provided for each window and three sets for each door.
4. Window Assembly – Braces are located horizontally approximately 1/3 of the distance from the top and the bottom of the window. Bolt holes are located 1/3 of the length of the brace from the outside edge of the window jams. Prior to installation, the assembly should be pre-assembled and 3/8” holes drilled through all of the components.
5. Door Assembly – Door braces will be placed horizontally; one in the center of the doorway and one 1/2 the distance from the center to the top and one 1/2 distance from the center to the bottom of the doorway. Bolt holes are located 1/3 of the length of the brace from the outside edge of the door frame. Prior to installation, the assembly should be pre-assembled and 3/8” holes drilled through all of the components.
6. Plywood used to cover exterior openings shall be nailed every 12" along the perimeter to the window or door frame.
7. The 2x4 braces on the interior and exterior of the assemblies shall be secured using 3/8” by 12” carriage bolt assemblies. Bolts shall be inserted through the pre-drilled holes from the exterior with a 1/2” washer place against the exterior brace, a 3/8” washer is placed against the interior brace. The bolt is tightened from the inside so that it slightly compresses the interior brace.
8. The exterior surfaces of barriers shall be painted or stained the same color as the structure to minimize the appearance.

Should the through-bolt compression method be impossible due to the size or condition of the opening, the opening shall be covered with plywood and secured with a minimum of 3-inch-long deck or wood screws installed on 4-inch centers around the circumference of the opening.

For buildings that require access by authorized personnel, a single door that is visible from the street may be secured using a solid core wood or steel door. There shall be no windows or other openings in this door. The door shall be securely locked using a padlock and hasp assembly that is bolted through the door. The lock loop portion of the hasp is attached to the door frame using a minimum of 3-inch-long wood screws.

Appendix 2 Building Security

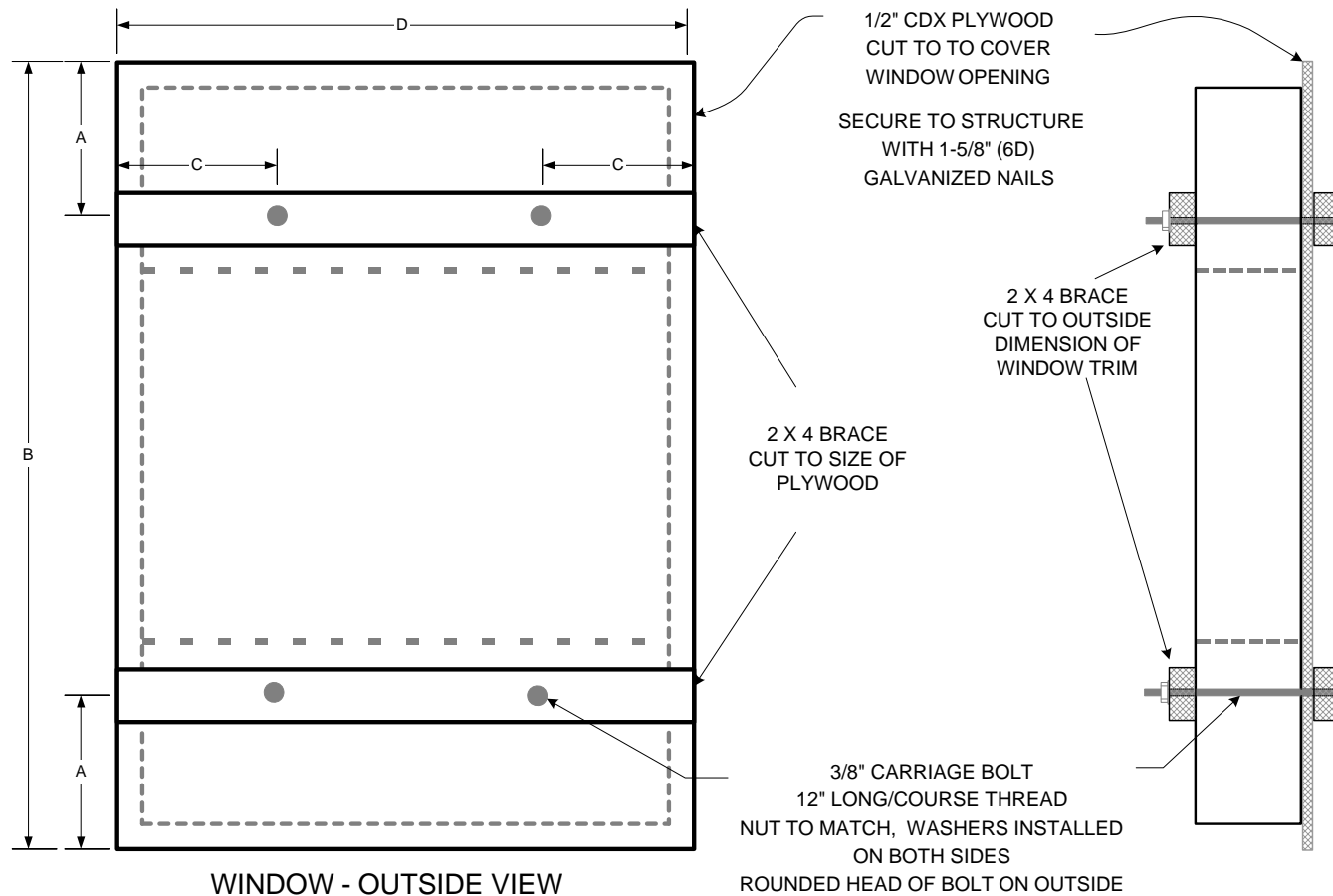

NOTES:

1. FOR DOUBLE HUNG WINDOWS, SLIDE SASH TO CENTER OF UNIT AND PASS BOLTS THROUGH OPENINGS AT TOP AND BOTTOM.
2. STORM WINDOWS SHOULD BE REMOVED AND STORED INSIDE STRUCTURE.
3. OUTSIDE TRIM MAY HAVE TO BE REMOVED TO ACCOMMODATE A FLUSH AND TIGHT FIT.
4. TIGHTEN NUTS FROM INSIDE ENOUGH TO SLIGHTLY COMPRESS 2X4 BRACE.
5. BRACE LOCATIONS: $A = 1/3 B$ (SEE DIMENSION LOCATIONS ON DRAWING)
6. LOCATION OF BOLT HOLES: $C = 1/3D$ (SEE DIMENSION LOCATIONS ON DRAWING)

USFA National Arson Prevention Initiative
Board Up Procedures

Window Detail



IAAI/USFA Abandoned Building Project



Appendix 2 Building Security

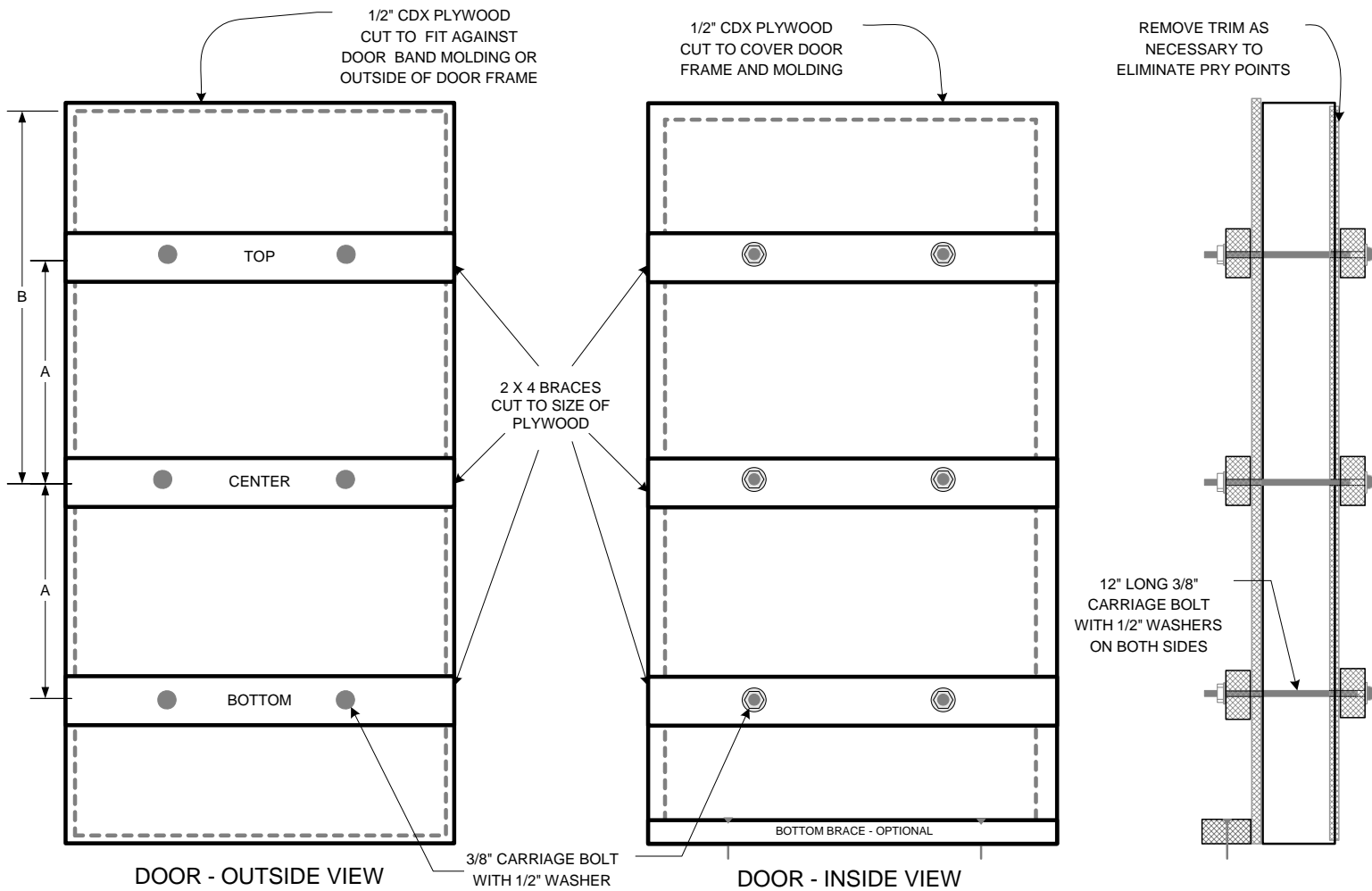



NOTES:

1. DOOR IS REMOVED AND STORED INSIDE BUILDING.
2. USE 3/8" X 12" CARRIAGE BOLTS - ROUNDED HEAD ON OUTSIDE OF BUILDING
3. TIGHTEN NUTS FROM INSIDE ENOUGH TO SLIGHTLY COMPRESS 2X4 BRACE.
4. IF PLYWOOD CAN NOT BE BUTTED AGAINST BAND MOLDING, CUT TO COVER OUTSIDE EDGE OF DOOR FRAME.
5. BOLT HOLES ARE LOCATED AS THEY ARE FOR WINDOWS (SEE WINDOW DETAIL)
6. CENTER BRACE LOCATED IN CENTER OF DOORWAY OPENING. TOP AND BOTTOM BRACES ARE POSITIONED WHERE $A = 1/2B$ (SEE DIMENSION LOCATIONS ON DRAWING)

USFA National Arson Prevention Initiative
Board Up Procedures

Door Detail

IAAI/USFA Abandoned Building Project

Appendix 2 Building Security

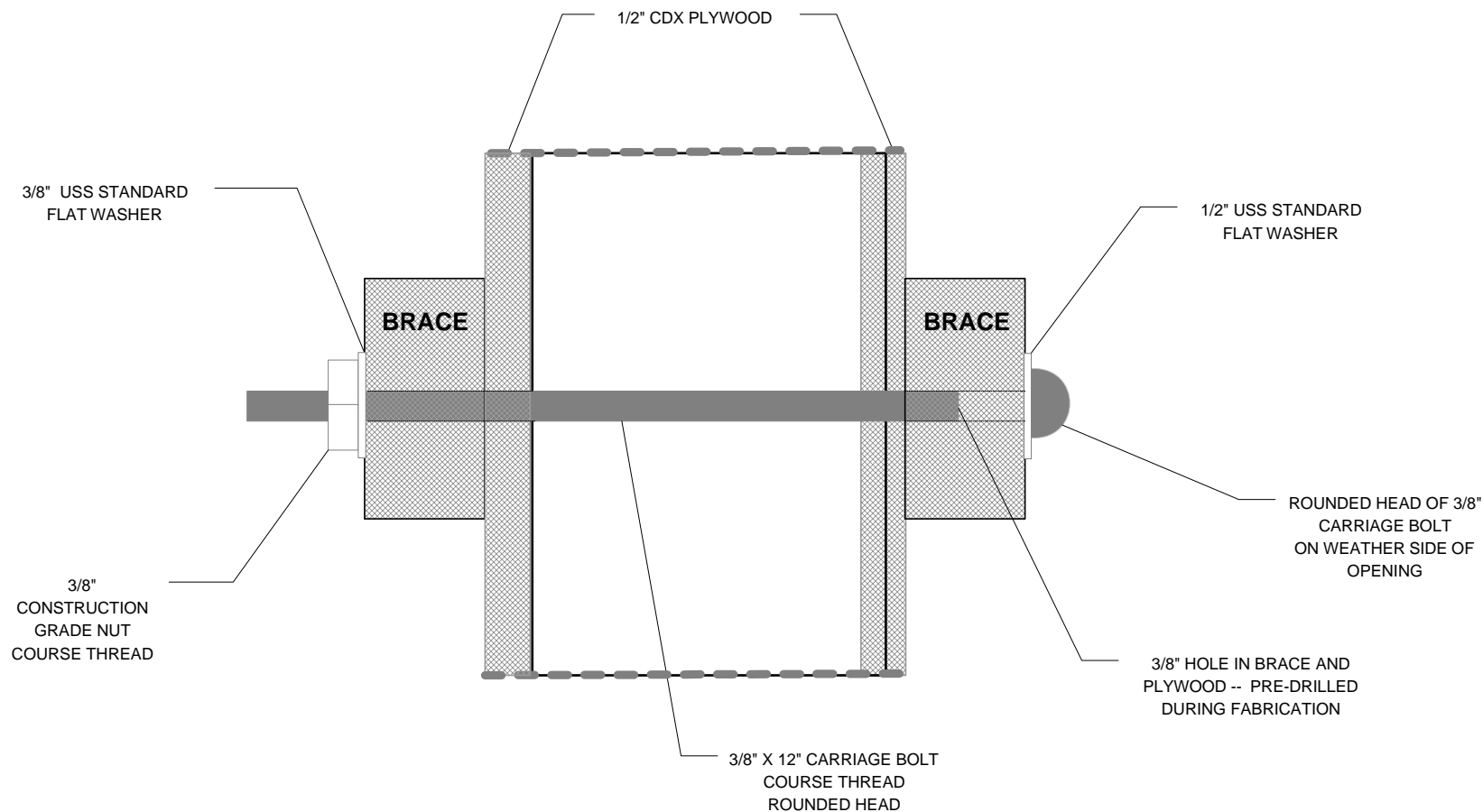

NOTES:

1. USE 3/8" X 12" CARRIAGE BOLTS - ROUNDED HEAD ON OUTSIDE OF BUILDING
2. TIGHTEN NUTS FROM INSIDE ENOUGH TO SLIGHTLY COMPRESS WASHER INTO 2X4 BRACE.
3. USE 1/2" WASHER ON WEATHER SIDE TO ACCOMMODATE THE THE WRENCH NECK OF BOLT AND ELIMINATE PRY POINTS.

USFA National Arson Prevention Initiative
Board Up Procedures
Bolt Assembly Detail
IAAI/USFA Abandoned Building Project



Appendix 2 Building Security

WINDOW ASSEMBLY

MATERIALS REQUIRED PER WINDOW

- 1 1/2" CDX PLYWOOD SHEET - CUT TO DIMENSIONS OF WINDOW FRAME (WEATHER SIDE)
- 4 2X4 BRACES - CUT TO WIDTH OF PLYWOOD
- 4 CARRIAGE BOLT ASSEMBLIES

DOOR ASSEMBLIES

MATERIALS REQUIRED PER DOOR

- 1 1/2" CDX PLYWOOD SHEET - CUT TO DIMENSIONS OF DOOR FRAME (WEATHER SIDE)
- 1 1/2" CDX PLYWOOD SHEET - CUT TO OUTSIDE DIMENSIONS OF DOOR FRAME TRIM (INSIDE)
- 6 2X4 BRACES - 3 CUT TO WIDTH OF OUTSIDE PLYWOOD, 3 CUT TO WIDTH OF INSIDE PLYWOOD
- 1 2X4 BOTTOM BRACE - CUT TO WIDTH OF DOOR TRIM (OPTIONAL)
- 6 CARRIAGE BOLT ASSEMBLIES

CARRIAGE BOLT ASSEMBLY

- 1 12' X 3/8" CARRIAGE BOLT - COURSE THREAD
- 1 1/2" USS STANDARD FLAT WASHER (WEATHER SIDE)
- 1 3/8" USS STANDARD FLAT WASHER (INSIDE)
- 1 3/8" CONSTRUCTION GRADE NUT - COURSE THREAD

NUMBER OF WINDOWS TO BE SECURED (N_w): _____

NUMBER OF WINDOWS BRACES REQUIRED: ($N_w \times 4$) _____

CARRIAGE BOLT ASSEMBLIES REQUIRED (B_w): ($N_w \times 4$) _____

NUMBER OF DOORS TO BE SECURED (N_d): _____

NUMBER OF DOOR BRACES REQUIRED: ($N_d \times 6$) _____

NUMBER OF BOTTOM BRACES REQUIRED: (N_d) _____

CARRIAGE BOLT ASSEMBLIES REQUIRED (B_d): ($N_d \times 6$) _____

TOTAL CARRIAGE BOLT ASSEMBLIES REQUIRED: ($B_w + B_d$) _____

USFA National Arson Prevention Initiative

Board Up Procedures

MATERIALS LIST

IAAI/USFA Abandoned Building Project



Appendix 3 Building Markings

These markings are based on the system used by FDNY in New York City. Other jurisdictions may utilize different marking systems. Building may be marked using signs or the marks may be painted on to outside walls of the building. Markings should be readily visible from normal access points of the building.

The sign depicted here is 2 ft x 2 ft and is printed on corrugated plastic sign stock.



Exterior operations only – Enter only for known life hazard



Interior operations permitted – Enter building with extreme caution